

# FP-108HH

254Øx89mm



## DESIGN FEATURES

- \***BEARING SYSTEM:** BALL BEARING
- \***IMPELLER:** PLASTIC WITH FIBER GLASS FILLED UL 94V-0
- \***HOUSING:** DIE CAST ALUMINUM PAINTED BLACK
- \***MOTOR:** CAPACITOR INDUCTION MOTOR
- \***PROTECTION:** THERMAL PROTECTION
- \***CONNECTING:** WIRE LEADS & TERMINAL
- \***OTHER VOLTAGE:** 100,200VAC(50/60Hz)ARE AVAILABLE

## DIMENSIONS:MM

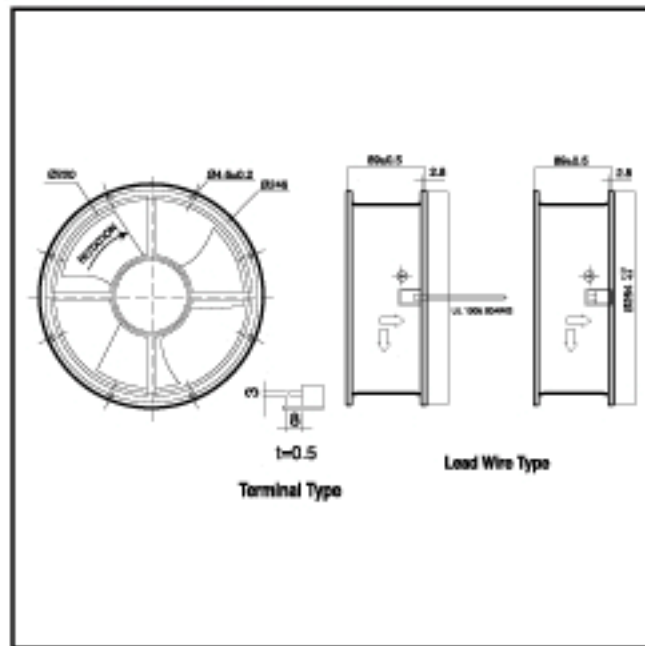

## PERFORMANCE

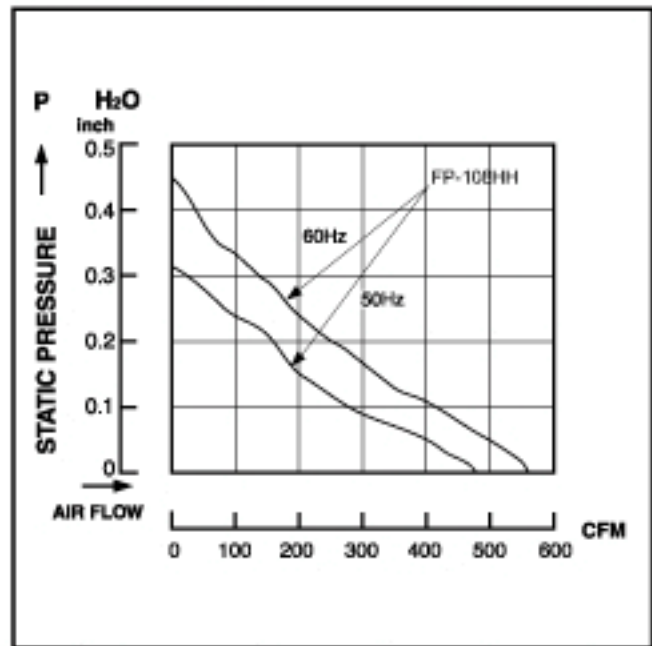

## SPECIFICATIONS

Specifications are subject to change without notice

MODEL NO.	VOLT (VAC)	FREQUENCY (HZ)	AIR (CFM)	VOLUME (M <sup>3</sup> /MIN)	CURRENT (A)	POWER (W)	SPEED (RPM)	STATIC PRESSURE (INCH-H <sub>2</sub> O)	NOISE (dBA)
FP-108HH	110/120	50/60	460/550	13.0/15.5	0.32/0.30	35/30	1500/1650	0.35/0.45	48
FP-108HH	220/240	50/60	460/550	13.0/15.5	0.15/0.14	33/31	1500/1650	0.35/0.45	48