

THIS DRAWING IS UNPUBLISHED. RELEASED FOR PUBLICATION. ALL RIGHTS RESERVED.

LOG	DIST	REVISIONS				
		#	DATE	DESCRIPTION	BY	APPV
CM	00	N3		REVISED PER ECR-15-006702	NK	PQ

LEADFREE	DIM A	NO. OF CIRCUITS	PART NO.
YES	71.12[2.800]	28	5-640441-8
YES	68.58[2.700]	27	5-640441-7
YES	66.04[2.600]	26	5-640441-6
YES	63.50[2.500]	25	5-640441-5
YES	60.96[2.400]	24	5-640441-4
YES	58.42[2.300]	23	5-640441-3
YES	55.88[2.200]	22	5-640441-2
YES	53.34[2.100]	21	5-640441-1
YES	50.80[2.000]	20	5-640441-0
YES	48.26[1.900]	19	4-640441-9
YES	45.72[1.800]	18	4-640441-8
YES	43.18[1.700]	17	4-640441-7
YES	40.64[1.600]	16	4-640441-6
YES	38.10[1.500]	15	4-640441-5
YES	35.56[1.400]	14	4-640441-4
YES	33.02[1.300]	13	4-640441-3
YES	30.48[1.200]	12	4-640441-2
YES	27.94[1.100]	11	4-640441-1
YES	25.40[1.000]	10	4-640441-0
YES	22.86[.900]	9	3-640441-9
YES	20.32[.800]	8	3-640441-8
YES	17.78[.700]	7	3-640441-7
YES	15.24[.600]	6	3-640441-6
YES	12.70[.500]	5	3-640441-5
YES	10.16[.400]	4	3-640441-4
YES	7.62[.300]	3	3-640441-3
YES	5.08[.200]	2	3-640441-2
NO	71.12[2.800]	28	2-640441-8
NO	68.58[2.700]	27	2-640441-7
NO	66.04[2.600]	26	2-640441-6
NO	63.50[2.500]	25	2-640441-5
NO	60.96[2.400]	24	2-640441-4
NO	58.42[2.300]	23	2-640441-3
NO	55.88[2.200]	22	2-640441-2
NO	53.34[2.100]	21	2-640441-1
NO	50.80[2.000]	20	2-640441-0
NO	48.26[1.900]	19	1-640441-9
NO	45.72[1.800]	18	1-640441-8
NO	43.18[1.700]	17	1-640441-7
NO	40.64[1.600]	16	1-640441-6
NO	38.10[1.500]	15	1-640441-5
NO	35.56[1.400]	14	1-640441-4
NO	33.02[1.300]	13	1-640441-3
NO	30.48[1.200]	12	1-640441-2
NO	27.94[1.100]	11	1-640441-1
NO	25.40[1.000]	10	1-640441-0
NO	22.86[.900]	9	640441-9
NO	20.32[.800]	8	640441-8
NO	17.78[.700]	7	640441-7
NO	15.24[.600]	6	640441-6
NO	12.70[.500]	5	640441-5
NO	10.16[.400]	4	640441-4
NO	7.62[.300]	3	640441-3
NO	5.08[.200]	2	640441-2

SUPERCEDED BY 5-640441-8
 SUPERCEDED BY 5-640441-7
 SUPERCEDED BY 5-640441-6
 SUPERCEDED BY 5-640441-5
 SUPERCEDED BY 5-640441-3
 SUPERCEDED BY 5-640441-1

OBSOLETE

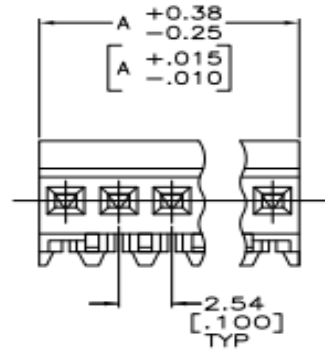
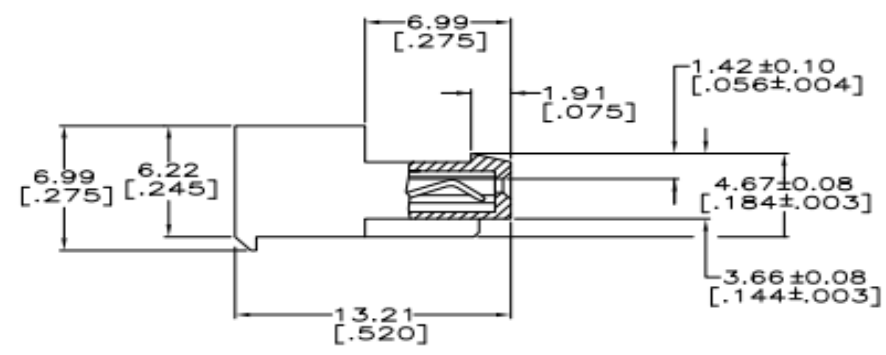
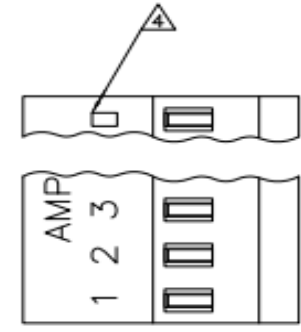

- △ MATERIAL: CONNECTOR - NYLON UL94V-2 (WHITE). CONTACTS - 0.30[.012] THICK COPPER ALLOY BRIGHT TIN-LEAD .00203[.000080] MIN THICKNESS FOR 640441-2 THRU 2-640441-8. MATTE WHISKER MITIGATED TIN .00203[.000080] MIN THICKNESS OVER NICKEL UNDERPLATE FOR 3-640441-2 THRU 5-640441-8.
- 2. CONTACTS ACCEPT 24 AWG WIRE WITH 1.52[.060] MAX INSULATION DIAMETER.
- 3. CONTACTS MUST ACCEPT 0.64±0.03[.025] POST AND REMAIN LOCKED IN POSITION.
- △ IDENTIFICATION NUMBER FOR LAST CIRCUIT MAY NOT APPEAR ON ALL ASSEMBLIES.
- 5. DIMENSIONS IN BRACKETS ARE IN INCHES.
- 6. HOUSING FEATURES ARE: CLOSED END WITH LOCKING RAMP.
- △ OBSOLETE PARTS: OBSOLETE CIS STREAMLINING PER D.RENAUD/D.SINISI

THIS DRAWING IS A CONTROLLED DOCUMENT.

DESIGNED BY: S. CARPENTER	DATE: 04/20/2003	 TE Connectivity	MTA-100 CONNECTOR ASSEMBLY, 24 AWG, STANDARD		
DRAWN BY: D. BOSSI	DATE: 04/20/2003				
APPROVED BY: D. BOSSI	DATE: 04/20/2003				
PRODUCT SPEC: 108-1050	APPLICATION SPEC: 114-1019				
MATERIAL: 1	FINISH: 1	SIZE: A2	CAGE CODE: 00779	DRAWING NO: C-640441	RESTRICTED TO: -
CUSTOMER DRAWING		SCALE: 5:1	SHEET: 1 of 1	REV: N3	